

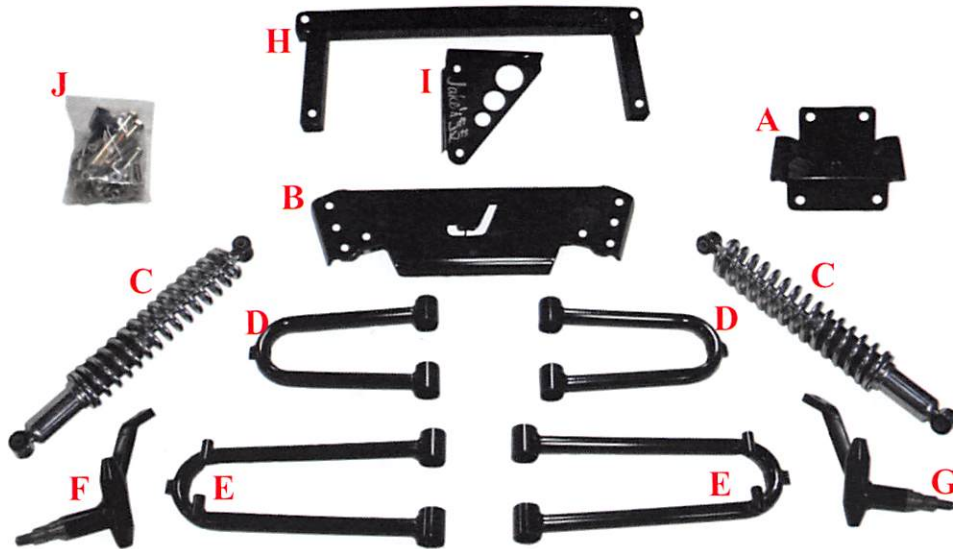

Yamaha G29Lift Kit
Long Travel Lift Kit Installation Instructions
Part# 7416
U.S. Pat. 7581740



ITEM	QTY
A. JAKE'S SUB-FRAME	1
B. J-PLATE/SHOCK MOUNT	1
C. SHOCKS	2
D. UPPER A-ARMS	2
E. LOWER A-ARMS	2
F. PASSENGER SIDE SPINDLE	1
G. DRIVER SIDE SPINDLE	1
H. REAR GOALPOST/ UPPER SHOCK MOUNT	1
I. REAR SWAY BAR MOUNT	1
J. HARDWARE KIT	1
K. WARNING LABEL (NOT PICTURED)	1

 *Always wear appropriate eye protection!*

FRONT ASSEMBLY

1. Remove the roof, front cowl, and front bumper from the car. Save all hardware for reinstallation.
2. Place the front of the car on jack stands and remove the wheels & tires. Make sure you raise the car high enough to accommodate the larger wheels and tires.
3. Remove the stock hubs, struts/shocks, and a-arms. Save the stock hubs and a-arm bolts for reinstallation.
4. Install supplied tie rod extensions, jam nuts, & tie rod ends from hardware kit (ITEM J) to the stock steering box on both driver side and passenger side of the car as shown in FIGURE 1.

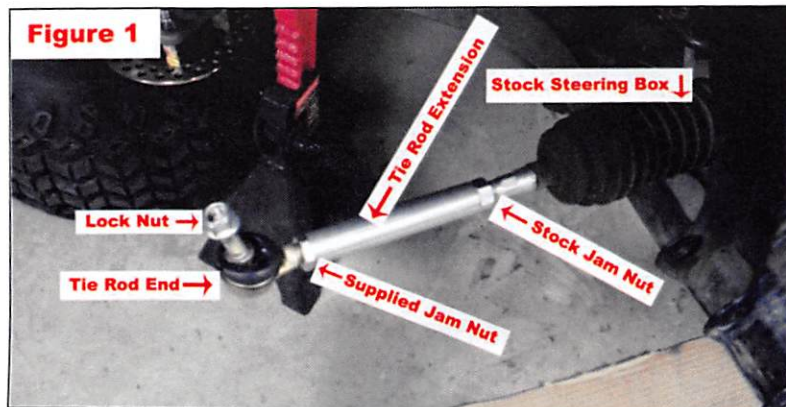

5. Using supplied 3/8 x 1 bolts, washers, & locknuts install sub-frame (ITEM A) to the stock cross member holes as shown in FIGURE 3.
6. Using a 3/8" drill bit and the sub-frame holes as a guide drill two 3/8" holes in the stock sub-frame as shown in FIGURE 2.

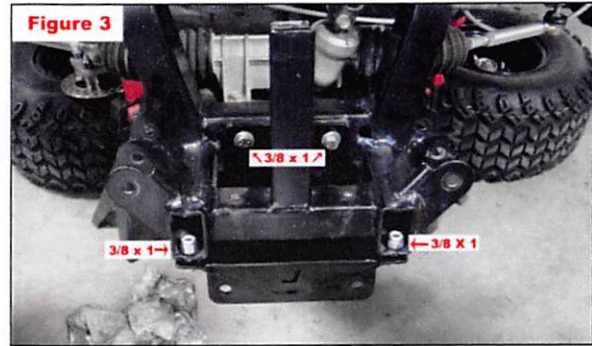
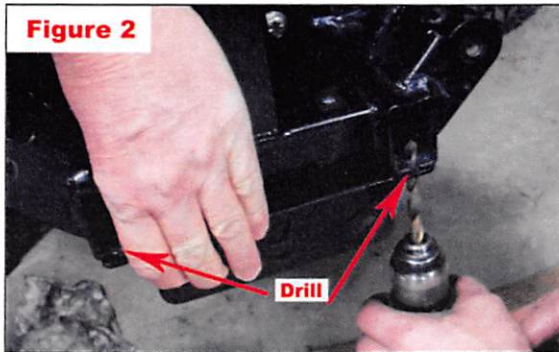

7. Using the supplied 3/8 x 1 bolts, washers, & locknuts install the sub-frame to the newly drilled holes in the stock sub-frame as shown in FIGURE 3.
8. Bolt the supplied J-Plate (ITEM B) to the stock upper shock mount holes using the supplied 3/8 x 1 bolts, washers, & locknuts as shown as shown in FIGURE 4.
9. Using the J-Plate (ITEM B) as a guide drill a 3/8" hole to both sides of the stock frame as shown in FIGURE 4.
10. Using the supplied 3/8 x 1 bolts, washers, & locknuts bolt the J-Plate (ITEM B) to the newly drilled holes in the stock frame as shown as shown in FIGURE 5.

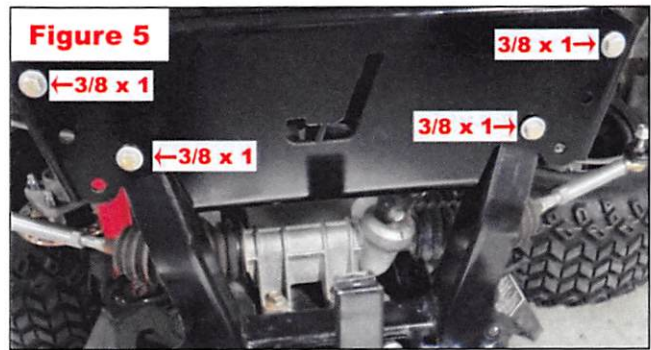
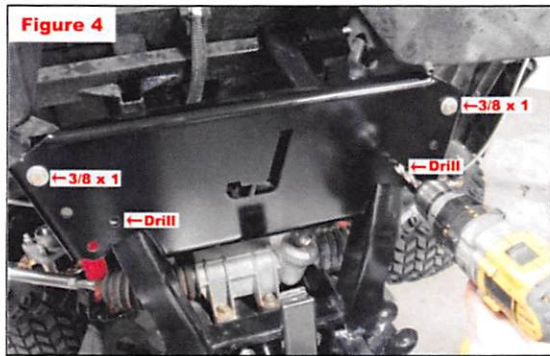

11. Install the lower a-arms (ITEM E) to the sub-frame (ITEM A) on both the driver and passenger side using the supplied 3/8 x 3 bolts and locknuts as shown in FIGURE 6. **NOTE: The a-arms are not side specific. The a-arms must be installed with the shock mount holes facing up as shown in FIGURE 6.**
12. Using the stock upper a-arm bolts, bolt the new upper a-arms (ITEM D) to the stock upper a-arm location on both the driver and passenger side as shown in FIGURE 6. **NOTE: The a-arms are not side specific. The a-arms must be installed with the threaded heim mount facing down as shown in FIGURE 6.**
13. Install the driver (ITEM G) and passenger (ITEM F) spindles to the a-arms using the supplied 1/2 x 7 bolt, locknut, & heim spacers as shown in FIGURE 7.

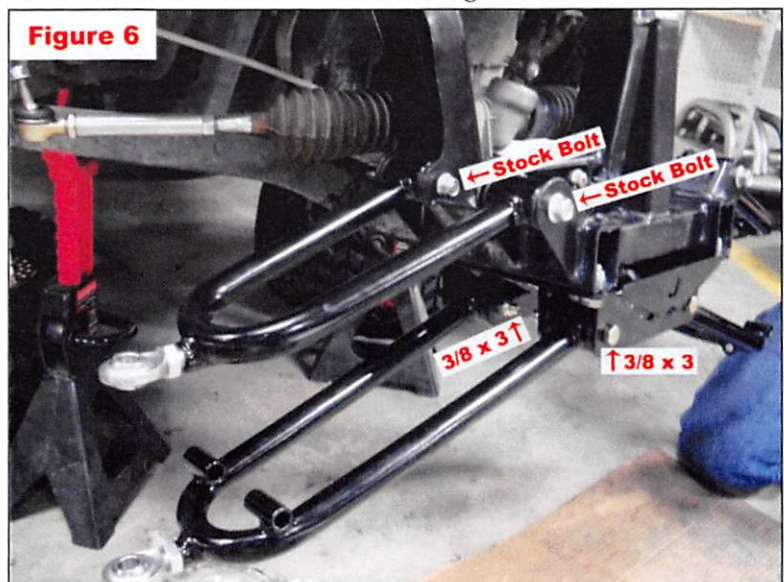

14. Install the bottom of the shocks (ITEM C) on both the driver and passenger side to the lower a-arms (ITEM E) using the supplied 7/16 x 5 bolts, locknuts, & bushing spacers as shown in FIGURE 9.
15. Install the top of the shocks (ITEM C) on both the driver and passenger side to the J-Plate (ITEM B) with the supplied 7/16 x 3 bolts, washers, locknuts, & tapered spacers as shown in FIGURE 8.
16. Attach the tie rod ends to the spindles as shown in FIGURE 7 on both the driver and passenger side using the supplied locknuts.
17. Reinstall the wheel hubs to the new spindles with the stock hardware.
18. Install Jake's recommended 22x11x10 or 23x10.5x12 tire on 3x5 offset wheels for maximum performance. **NOTE: Your stock wheels and tires will NOT work!**
19. Securely tighten all bolts.
20. Supplied is a warning label (ITEM K) that is to be placed on the car in a visible area that is to be read by any and all passengers and drivers.
21. Lower the cart back to the ground. Caster/camber adjustments can be made by adjusting both the upper and lower heim joints on the a-arms. Set toe to approximately 1/8" in by loosening the jam nuts on the tie rod extensions and lengthening or shortening the tie rods. Retighten jam nuts once toe is set.
22. Reinstall front cowl and top.

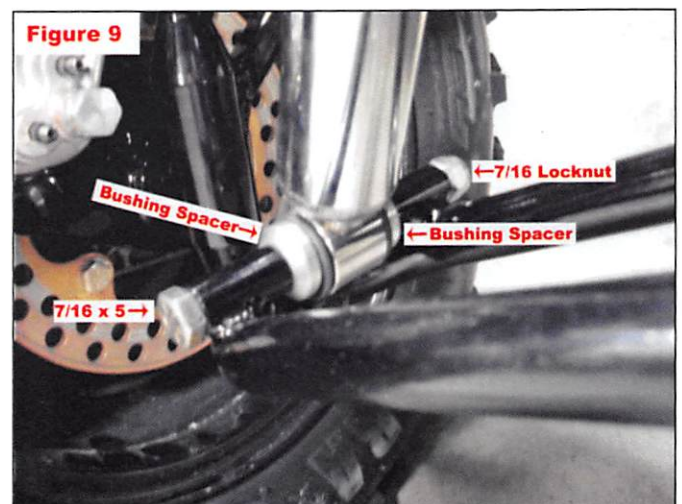
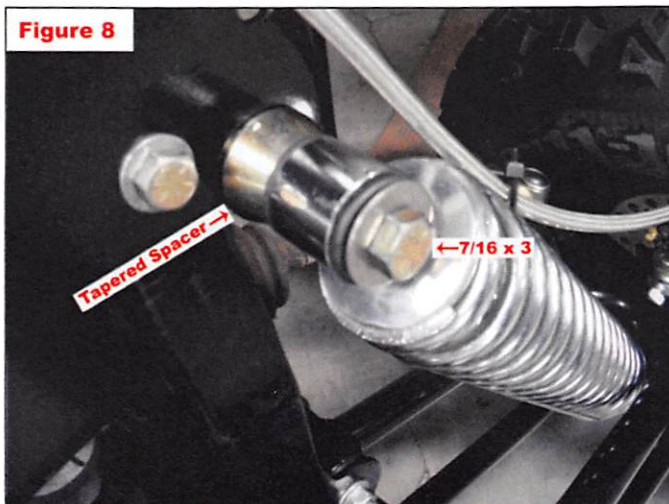
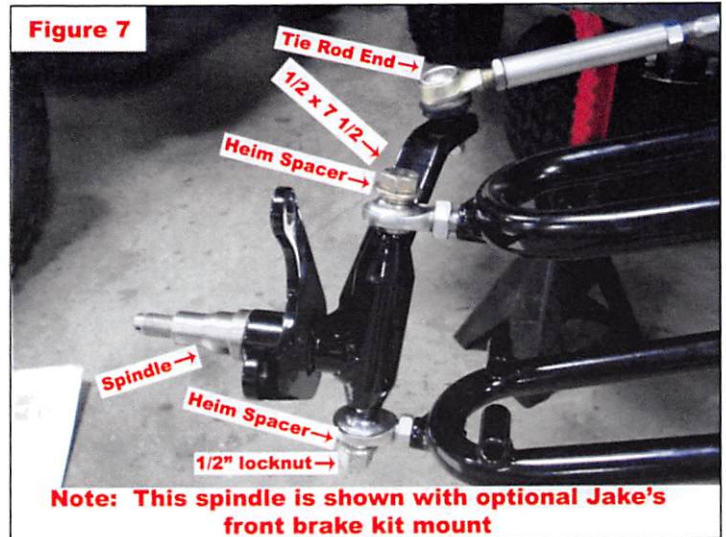

REAR INSTALLATION

1. Remove the rear body assembly if necessary. (Not all bodies will require removing.)
2. Remove the rear sway bar at the frame end. (Driver's side)
3. Raise the rear of the cart and place the frame on jack stands. (Make sure you raise cart high enough for larger tires.)
4. Remove the rear tires.
5. Remove the rear shocks.
6. Install JAKES rear goalpost (ITEM H) to the TOP stock shock mount location as shown using the stock upper shock mount bolts. **NOTE: The "J" in the center of the rear goalpost should be facing the rear of the cart.**
7. Install the shock to the goalpost using the supplied 3/8 x 2 bolts and locknuts as shown. (You may have to oversize the lower shock mount holes enough to eliminate shock bind.)
8. Install JAKES new triangular shaped sway bar bracket (Item I) to the driver's side of the cart using the supplied 3/8 x 3 & 1/2 x 1 bolts and locknuts as shown. Reconnect the sway bar. (Some carts may require enlarging the left rear bag-well hole down through the frame with a 3/8" drill bit to secure the sway bar.)
9. Securely tighten all bolts.
10. Install your new wheels and tires and lower cart to the floor. **NOTE: Your stock wheels and tires will NOT work!**
11. Install the rear body assembly if needed.
12. Make sure you have enough length for the choke cable, ground wires, vacuum lines, fuel lines and the electrical wire. (The choke in some cases, may need lowered in the body 1 - 2" and remounted for adequate length.)
14. Double check all of the bolts for tightness.

NOTE: Inner fenders & rockers may need heated, reformed or cut for tire clearance.

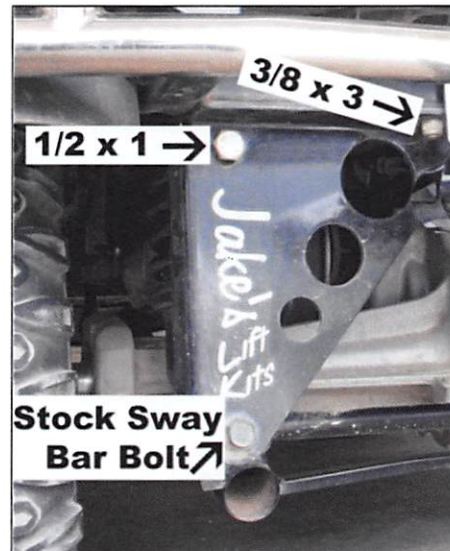
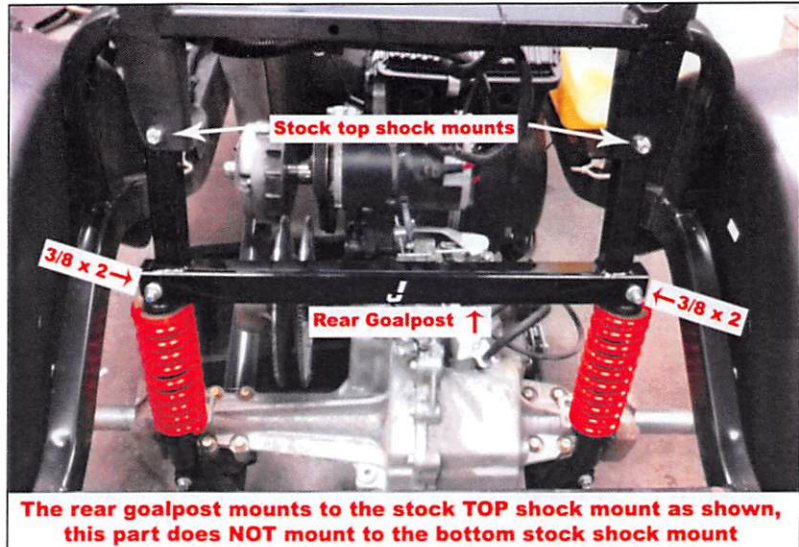

Indemnification And Insurance Agreement

High Performance Enhancement Kit purchaser assumes sole and entire responsibility for, and shall indemnify and save harmless Nivel LLC, from any and all claim, liability, responsibility, and persons or property that may be sustained in connection with the use of any product before or after purchase, including but not limited to high performance enhancement lift kits. The High Performance Enhancement Kit purchaser also shall indemnify Nivel LLC harmless with respect to any and all liability that may be incurred.

Golf Cars are recommended for use only by those aged 16 and older. Golf Cars can be especially hazardous to operate. Always remember that riding and alcohol/drugs don't mix. Never ride on public roads. Never carry more than two passengers (except shuttles and trams). Never engage in stunt driving. Avoid excessive speeds and be particularly careful on difficult terrain. Nivel LLC reserves the right, at any time, to discontinue or change specifications, prices, designs, features, models, or equipment without notice and without incurring any obligation.